

otobil machine



**AUTOMOTIVE TECHNOLOGY
SPECIAL PRODUCTION TEST DEVICES AND
INSPECTION STATIONS EQUIPMENT**

www.otobilmachine.com



About us

Otobil Makine Sanayi is a manufacturing company that has been registered by many users and companies in Turkey and abroad by leading the sector for 20 years. In 15 different countries, the equipment produced by Otobil Makine is actively used by the machine users. Main reference countries around the world; Austria, Germany, Azerbaijan, Serbia, Kazakhstan, Bosnia-Herzegovina, Saudi Arabia, Cyprus, Iraq and Uzbekistan.

Otobil Makina has reached the pinnacle of expertise in the industry, becoming a brand that consistently performs its duties with dedication, placing customer satisfaction at the forefront throughout the years.

The expert team of Otobil Makina consists of experienced professionals equipped with years of experience. This professional team, each specialized in their own field, produces high quality test and diagnostic equipment using the latest technology. While producing according to the demands of the automotive sector and various types of vehicles, it also continuously conducts its activities and R&D efforts according to future technologies rather than just the needs of the present day.

Otobil Makina, which has been growing steadily for 20 years and progressing with the slogan “You dream it, we build it”, continues to make a name for itself in the sector with its vehicle inspection devices produced in world standards and incorporating the latest technology.



Our Mission

By providing the highest quality products and services to our customers, to ensure their trust and satisfaction, to provide a fair and supportive working environment for our employees, to operate in a socially and environmentally sensitive manner, and to continuously work to develop innovative and sustainable solutions. To maintain leadership in the sector with its customer- orientated approach and to continue to add value to its stakeholders.



Our Vision

To become a globally recognized brand by offering innovative solutions in the automotive industry. To continuously invest in advanced technology to meet the needs of its customers and to shape the automotive industry of the future by maintaining its leadership in the sector.



Our Values

Otobil Makina believes that it can exist as long as its country exists and trusts its country and its people to the end. With an unshakable belief in the power of domestic production, it works to contribute to the national economy and create added value in all its works.

Focus on the Customer::

Ensuring customer satisfaction under the best possible conditions by striving to fully meet their requests and expectations.

Business Ethics:

Being honest and open in business and social relationships.

Respectful of the environment and society:

To meet all legal requirements on the environment, to control, reduce and prevent factors that may cause environmental pollution.

Resource Management and Efficiency:

To bring efficiency to the forefront by optimizing the use of all kinds of resources in all processes and to ensure sustainable development.

Participatory management approach:

To maintain and develop a management approach that is based on respectful and open communication with its employees, prioritizing participation in decision-making mechanisms.

Teamwork:

To ensure employee participation at every stage of its activities, to continuously improve with team spirit by working with the awareness of “we” rather than “me”.



01





**AUTOMOTIVE TECHNOLOGY
SPECIALISED PRODUCTION TEST
EQUIPMENT AND INSPECTION
STATION EQUIPMENT**



4X4 SYNCHRONISED SYSTEM

VEHICLE INSPECTION STATION TEST SET

Technology devices equipped with international standards provide the opportunity for detailed vehicle fault detection and reporting, **“particularly for electric and hybrid vehicles”**

Included in the package are Brake Test Devices, Suspension Test Devices, Dynamometer Test Devices, Lateral Slip Test Devices, and additional equipment, allowing for the inspection and reporting of various vehicles, **including electric and hybrid vehicles**, as well as 4x2 and 4x4 passenger cars, SUVs, off-road vehicles, and commercial vehicles. Upon request, a synchronized 4x4 dyno test device can be produced without brake, suspension, and lateral slip test devices.

Package Contents:

- Brake Test Device
- Suspension Test Device
- Lateral Slip Test Device
- Dynamometer Test Device (Fixed)
- Dynamometer Test Device (Mobile)
- Synchronized Test System
- Cooling Fan 9700m³
- Connection Equipment
- Electronic Brain
- Compressor 47lt.
- Computer Stand
- V2 Software Support

Optional Products and Services:

- Floor Mounting
- Ramp
- Cooling Fan 27000m³
- Retarder System
- V3 Software Support
- ERP and API support
- Barcode Reading System
- Mobile Application



Below you can find the malfunctions that can be detected with the test devices included in this set.

Malfunctions that can be detected with 4x4 Synchronised Test Device:

- Instantaneous ECU brain checks and faults.
- Voltage checks and faults during electric movement.
- Acceleration and operating faults in hybrid electric and gas-powered vehicles.
- Parameter checks and faults while driving
- Vehicle front end assemblies.
- Turbo Intercooler
- Gear shifting.
- Transmission
- Clutches
- Clutch system
- Ignition system
- Fuel system
- Exhaust outlets
- Instrument panels
- OBD2 and ECU
- 4-drawer control
- Differential system control



Malfunctions that can be detected with Brake Test Device:

- Detection of brake drums or callipers with braking difference and loss of holding force.
- Detection of disc lining friction and failures in the holding efficiency of the wheel on the road in proportion to the weight of the vehicle with braking efficiency
- Ovality (curvature test) to detect oscillations that may be caused by the brake disc.
- Control of the handbrake assembly with the handbrake test.
- Detection of the reaction and oscillations of the cyclic movement in the graphics with pedal force measurement.

Malfunctions that can be detected with Suspension Test Device:

- Springs
- Shock absorbers
- Suspension systems
- Balance bars
- Rotils

Malfunctions that can be detected with the sideslip test Device:

- Gaps between tie rods and vehicle axle
- Wheel Alignment
- Axle Positions
- Irregularities in Vehicle Lateral Slip



4X4 STANDARD SYSTEM

VEHICLE INSPECTION STATION TEST SET

Within the scope of the vehicle inspection station, your business offers detailed vehicle fault detection and reporting capabilities with state-of-the-art equipment equipped with international standards.

Included in the package are Brake Test Machines, Suspension Test Machines, Dynamometer Test Devices, Lateral Slip Test Devices, and additional equipment, allowing for the inspection and reporting of various vehicles, including 4x2 and 4x4 passenger cars, SUVs, off-road vehicles, and commercial vehicles.

Package Contents:

- Brake testing machine
- Suspension testing machine
- Side slip tester
- Dynamometer tester (fixed)
- Dynamometer tester (mobile)
- 9700m³ cooling fan
- Connection equipment
- Electronic brain
- Compressor 47lt.
- Computer support
- Software support V2
- V2 Yazılım Desteđi

Optional Products and Services:

- Floor mounting
- Ramp
- Cooling fan 27000m³
- Slow-down system
- Synchronized system
- V3 software support
- Barcode reading system
- ERP and API support
- Mobile application



Below you can find the malfunctions that can be detected with the test devices included in this set.

Malfunctions that can be detected with 4x4 Dynamometer Test device:

- Vehicle front sets
- Turbo Intercooler
- Gear Shifts
- Power transmission
- Clutches
- Clutch System
- Ignition system
- Fuel system
- Exhaust gas outlets
- Dashboards
- OBD2 and ECU
- 4-drawer control
- Differential system control



Malfunctions that can be detected using a brake tester:

- Detection of brake drums or callipers showing a difference in braking and a loss of holding force.
- Detection of disc lining friction and deficiencies in wheel holding power on the road as a function of vehicle weight and braking power.
- Ovality (curvature test) to detect oscillations that may be caused by the brake disc.
- Checking the handbrake assembly with the handbrake test.
- Detection of the reaction and oscillations of the cyclic movement in the graphics with measurement of the pedal force.

Malfunctions that can be detected with the Suspension Test Device:

- Springs
- Shock absorbers
- Suspension systems
- Balance bars
- Rotils

Malfunctions that can be detected with the Lateral Slip Test Device:

- Gaps between tie rods and vehicle axle
- Wheel Alignment
- Axle Positions
- Irregularities in Vehicle Lateral Slip





4X2 STANDARD SYSTEM

VEHICLE INSPECTION STATION TEST SET

Within the scope of the vehicle inspection station, your business offers the opportunity for detailed vehicle fault detection and reporting using state-of-the-art equipment equipped with international standards.

Included in the package are Brake Test Machines, Suspension Test Machines, Dynamometer Test Devices, Lateral Slip Test Devices, and additional equipment, allowing for the inspection and reporting of passenger cars (both 4x2 and SUVs), off-road vehicles, and commercial vehicles.

Package Contents:

- Brake Test Machine
- Suspension Test Machine
- Lateral Slip Test Machine
- Dynamometer Test Machine (Fixed)
- 9700m³ Cooling fan
- Connection Equipment
- Electronic Brain
- Compressor 47 lt
- Computer Stand
- V2 Software Support

Optional Products and Services:

- Floor mounting
- Ramp
- Cooling fan 27000m³
- Retarder System
- V3 Software support
- Barcode Reading system
- ERP and API support
- Mobile application



Below you can find the malfunctions that can be detected with the test devices included in this set.

The Malfunctions that can be detected with 4x2 Dynamometer Test Device:

- Vehicle front sets
- Turbo intercooler
- Gear change
- Power transmission
- Clutches
- Clutch System
- Ignition System
- Fuel System
- Exhaust gas outlets
- Dashboards
- OBD2 and ECU
- Differential system control



Malfunctions that can be detected with Brake Test Machine:

- Detection of brake drums or callipers with braking difference and loss of holding force.
- Detection of disc lining friction and failures in the holding efficiency of the wheel on the road in proportion to the weight of the vehicle with braking efficiency.
- Ovality (curvature test) to detect oscillations that may be caused by the brake disc.
- Control of the handbrake assembly with the handbrake test.
- Detection of the reaction and oscillations of the cyclic movement in the graphics with pedal force measurement.

Malfunctions that can be detected with Suspension Test Machine:

- Springs
- Shock absorbers
- Balance Bars
- Rotils

Malfunctions that can be detected with the Lateral Slip Tester:

- Gaps between tie rods and vehicle axle
- Wheel alignment
- Axle positions
- Defects in the lateral slip of the vehicle

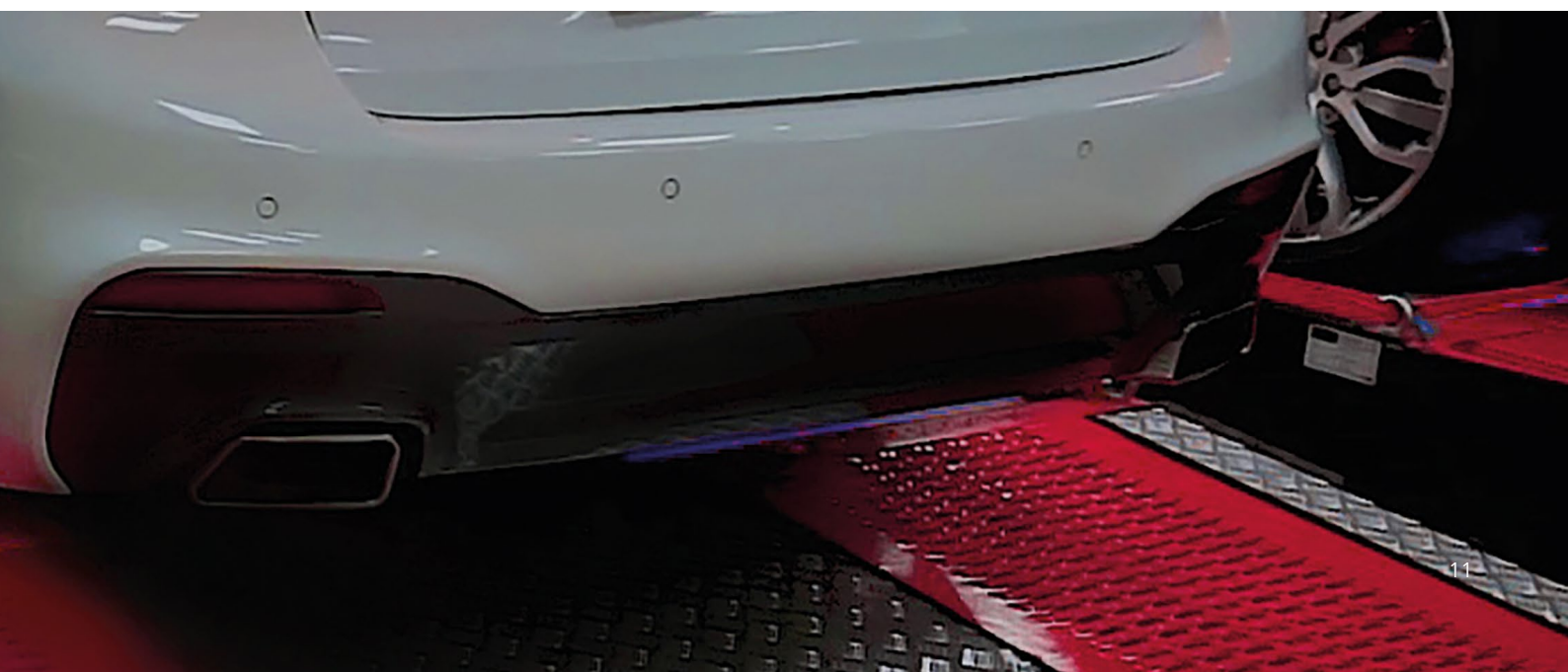



TRACTORS AND CONSTRUCTION MACHINERY

INSPECTION STATION TEST SET

This test kit consists of a complete set of malfunction detection and calibration test devices designed to meet the requirements of tractor manufacturers or construction equipment vehicles for special requests, multi-functional production lines or repair services.

Special test scenarios prepared according to the main needs of tractors and construction equipment make it possible to accurately detect faults and determine capabilities.

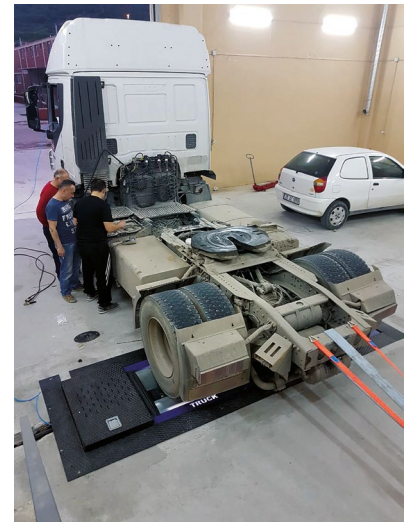

Contents of the Tractor Inspection Station Set:

- **PTU Speed Measuring Device** is used to control the instantaneous speed values of the tractor.
- **Damper Measuring Device** is used for leakage test and maximum-minimum capacity test on the hydraulic unit. With the electronic lifting unit, the maximum and minimum capacities of the tractor are measured and the necessary parts can be checked, repaired or replaced if the reference values are up or down. The system can be fixed at the requested load tonnage and the potential leaks in the unit can be detected by calculating the percentage decrease from the reference value within the specified time.
- **The dynamometer test device** can be used to instantly measure and monitor the rotation speeds, acceleration times and acceleration differences of all wheels.



Package contents:

- Dynamometer Test Device (Fixed)
- Dynamometer Test Device (Mobile)
- Damper Test Measurement Device (Manometer hydraulic 0-250 bar)
- PTU Speed Measurement Device
- Damper Lifting Measurement Device (0-8000 Kg)
- Connection Equipment
- Electronic Brain
- Compressor 47 liters
- Computer Stand
- V2 Software Support

Opsiyonel Ürün ve Hizmetler:

- Above-Ground Installation Service
- Ramp
- Brake Testing Machine
- Suspension Testing Machine
- Lateral Slip Test Device
- Synchronized Testing System
- Cooler Fan 9700m³
- Cooler Fan 27000m³
- Retarder System
- V3 Software Support
- Barcode Reading System
- ERP and API Support
- Mobile Application

Below you can find the malfunctions that can be detected with the test devices included in this set.

Malfunctions that can be detected with the dynamometer test device:

- Gear Shifts
- Transmission
- Clutches
- Clutch System
- Fuel System
- Exhaust Gas Outlets
- Instrument Panels
- OBD2 and ECU
- 4 Drawer Control
- Differential System Control

Malfunctions that can be detected with the PTU Speed Measurement Device:

- Incompatibilities and malfunctions between the current brain and the speedometer.

Faults that can be detected with Damper Test Measuring Device:

- Possible leakage and leakage failures of hydraulic pistons in the hydraulic unit.
- Difference between reference values and capacity values of the hydraulic system at maximum power.

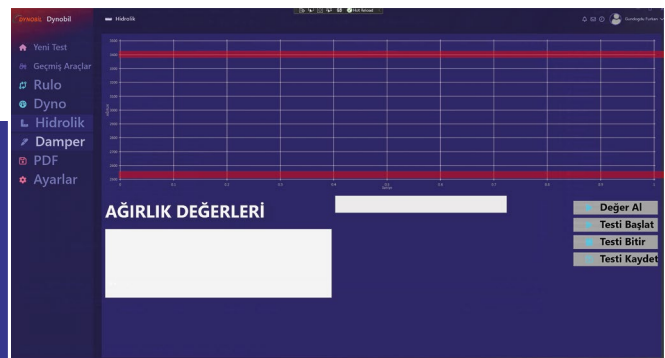
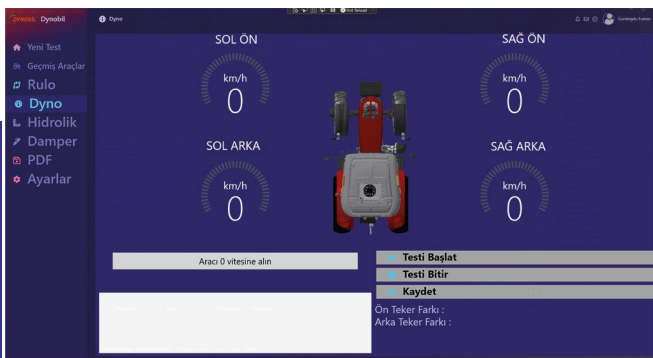



MOTORBIKE ROLL TEST

INSPECTION STATION TEST SET

The motorcycle inspection station offers detailed fault detection and reporting with the latest technology devices equipped with international standards.

Created with a test track for 3-wheeled motorcycles and 2-wheeled motorcycles, the set includes Brake Test Machine, Dynamometer Test Device and Lateral Slip Test Device.

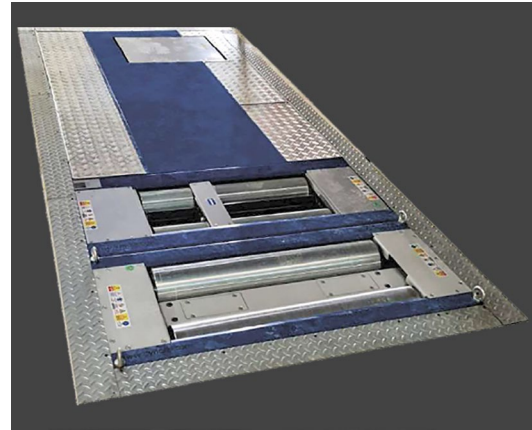

Package content:

- Brake Test Machine
- Lateral Slip Test Machine
- Dynamometer Test Device (Fixed)
- Cooling Fan 9700m³
- Connection Equipment
- Electronic Brain
- Compressor 47lt.
- Computer Stand
- V2 Software Support

Optional Products and Services:

- Floor Mounting
- Ramp
- Cooling Fan 27000m³
- Suspension Test Machine
- Retarder System
- V3 Software Support
- Barcode Reading System
- ERP and API support
- Mobile Application
- Robotic Arm
- Safety Sensors



Below you can find the malfunctions that can be detected with the test devices included in this set.

Malfunctions that can be detected with the Dynamometer Test Device:

- Ovality in Wheel Rotation
- Turbo Intercooler
- Gear Shifts
- Transmission
- Clutches
- Clutch System
- Ignition System
- Fuel System
- Exhaust Gas Outlets
- Dashboards
- OBD2 and ECU

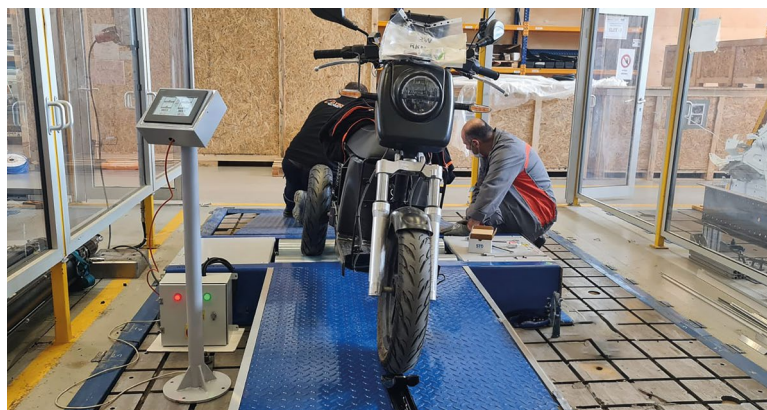

Malfunctions that can be detected with Brake Test Machine:

- Detection of brake calipers with braking difference and loss of holding force.
- Detection of disc lining friction and failures in the holding efficiency of the wheel on the road in proportion to the weight of the vehicle with braking efficiency.
- Detection of oscillations that may be caused by the brake disc with ovality (curvature test).
- Control of the handbrake assembly with the handbrake test.

Malfunctions that can be detected with Suspension Test Machine:

- Springs
- Shock Absorber
- Hanger Systems
- Balance Bars





MOTORBIKE PERFORMANCE TEST

(MOTORBIKE POWER MEASUREMENT DEVICE)

The Motorcycle Performance Test Set provides detailed vehicle fault detection and reporting with the latest technology devices equipped with international standards.

A test track has been created for high performance motorcycles and there is a Dynamometer Test Device with Magnetic Braking (Retarder System) in the set. With this test system, performance tests of your motorbike can be performed with the desired scenario and conditions.



Package contents:

- Dynamometer Test Device (Fixed)
- Retarder System
- Cooling Fan 9700m³
- Connection Equipment
- Electronic Brain
- Compressor 47lt
- Computer Stand
- V2 Software Support

Optional Products and Services:

- Floor Mounting
- Cooling Fan 27000m³
- Suspension Test Machine
- Brake Test Machine
- lateral Slip Test Machine
- V3 Software Support
- Barcode Reading System
- ERP and API support
- Mobile Application

Malfunction that can be detected with the Dynamometer Tester:

- Ovals in the wheel rotation
- Turbo Intercooler
- Gear Shifts
- Transmission
- Clutches
- Clutch System
- Ignition System
- Fuel System
- Exhaust Gas Outlets
- Dashboards
- OBD2 and ECU

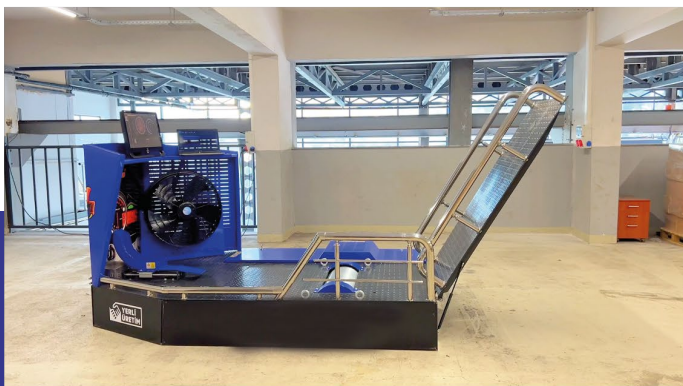



MOBILE VEHICLE - MOBILE LORRY

INSPECTION STATION TEST SET

The Mobile Vehicle Inspection Station offers detailed vehicle fault detection and reporting in a trailer equipped with the latest technology devices in international standards.

The Brake Test Machine, Suspension Test Machine, Dynamometer Test Equipment, Lateral Slip Tester and additional equipment included in the package, 4x2 and 4x4 passenger cars, SUVs, off-road vehicles and commercial vehicles are also checked and reported.

The mobile vehicle inspection station provides mobile vehicle inspection station services to the places where the fleet vehicles are located in the auto markets with on-site expertise service and in all regions of the world where there is the possibility of vehicle entry to be served.

Package contents:

- Dynamometer Test Device (Fixed)
- Dynamometer Test Device (Movable)
- Brake Test Machine
- Suspension Test Machine
- Lateral Slip Test Machine
- Cooling fan 9700m³
- Connection Equipment
- Electronic Brain
- Compressor 47lt.
- Computer Stand
- V2 Software Support

Optional Products and Services:

- Floor Mounting
- Ramp
- Cooling fan 27000m³
- Synchronized System
- V3 Software Support
- ERP and API support
- Barcode Reading System
- Mobile Application



Below you can find the malfunctions that can be detected with the test devices included in this set.

Malfunctions that can be detected with 4x4 Dynamometer Test Device:

- Vehicle Front Sets
- Turbo Intercooler
- Gear Shifts
- Transmission
- Clutches
- Clutch System
- Ignition System
- Fuel System
- Exhaust Gas Outlets
- Dashboards
- OBD2 and ECU
- 4 Drawer Control
- Differential System Control



Malfunctions that can be detected with Brake Test Machine:

- Detection of brake drums or calipers with braking difference and loss of holding force.
- Detection of disc lining friction and failures in the holding efficiency of the wheel on the road in proportion to the weight of the vehicle with braking efficiency.
- Ovality (curvature test) to detect oscillations that may be caused by the brake disc.
- Control of the handbrake assembly with the handbrake test.
- Detection of the reaction and oscillations of the cyclic movement in the graphics with pedal force measurement.

Malfunctions that can be detected with Suspension Test Machine:

- Springs
- Shock absorbers
- Hanger Systems
- Balance Bars
- Rotils

Malfunctions that can be detected with the Lateral Slip Test Device:

- Gaps between tie rods and vehicle axle
- Adjustment of wheel arrangement
- Axle positions
- Vehicle sideslip disturbances



02

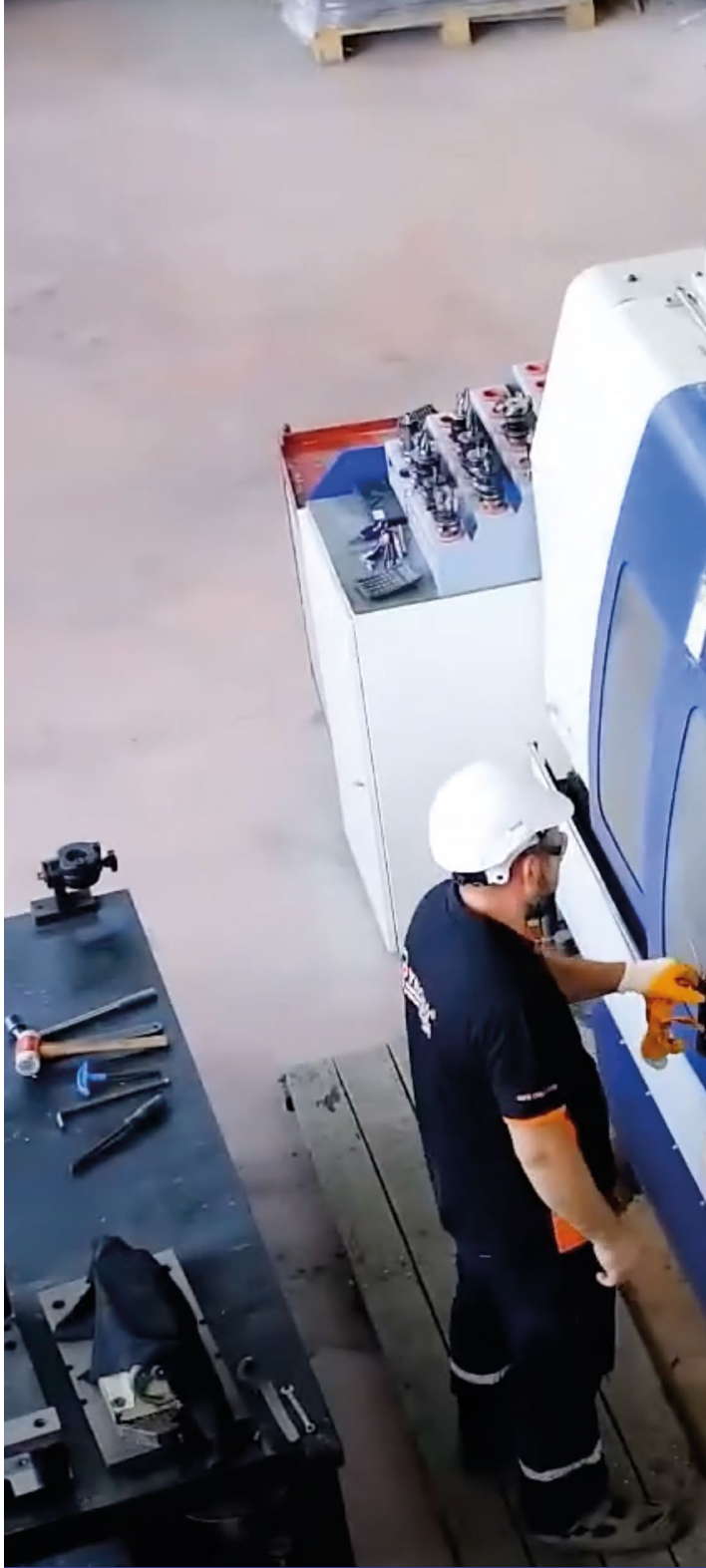

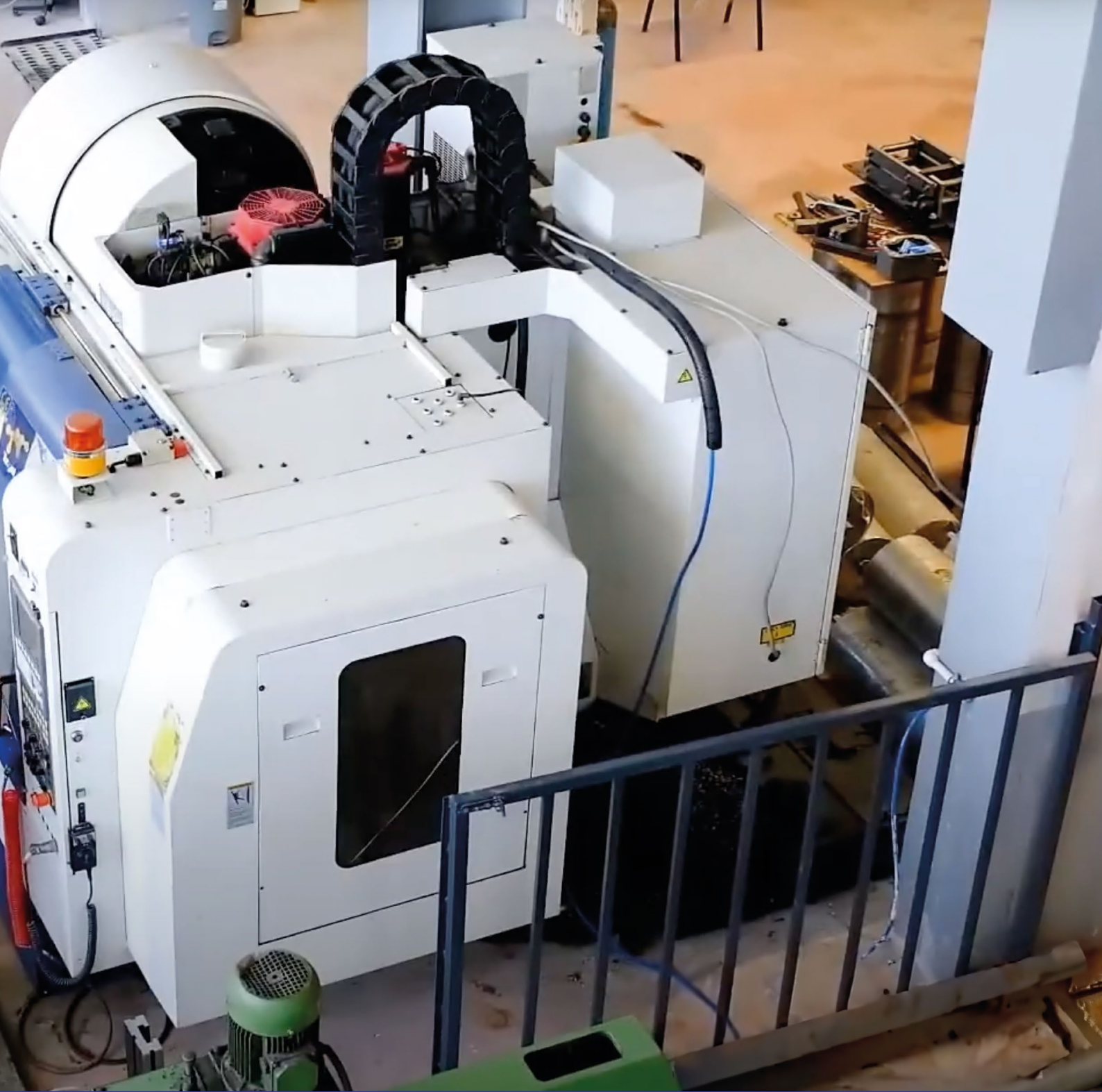

**OTOMOTIVE TECHNOLOGY
TEST EQUIPMENT
PRODUCTION**

DYNAMOMETER TEST MACHINE (ENGINE POWER AND PERFORMANCE TEST MACHINE)

The measurement of the circular motion that occurs as a result of the transmission of the power produced by the engine of the vehicle to the tires through the drivetrain is called dyno (dynamometer).

The Dynamometer Test Device is designed to measure the performance of the vehicle by providing sufficient air flow without causing any damage to the vehicle. Although it is generally referred to as a performance tester, its main purpose is to perform a road simulation that provides a safe driving environment. The basis of its usage areas, especially the performance values of the vehicle, is provided for fault detection.

The following measurements are made with the Dynamometer Test Device:

- Min-Max Wheel Power (kw)
- Lost Power (kw)
- Total Horsepower (hp)
- Min-Max Torque (Nm)
- Acceleration Time
- Cycle Intervals
- Performance Percentage
- Acceleration

Malfunctions that can be detected with the Dynamometer Test Device:

- Vehicle Front Sets
- Turbo Intercooler
- Gear Shifts
- Transmission
- Clutches
- Clutch System
- Ignition System
- Fuel System
- Exhaust gas outlets
- Dashboard
- OBD2 and ECU

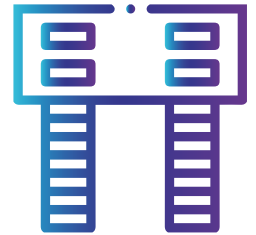

Technical Specifications

Driving Direction	Double Direction
Measurement Accuracy	±%1
Axle Weight	3.500 kg
Weight	2.000 kg
Maximum Measurement Speed	450 km/s
Maximum Measurable Power (with Retarder)	>800 Hp
Maximum Measurable Power	800 Hp
Fixed Dynamometer Measure	2500x90x36 mm
Movable Dynamometer Measure	2500x90x36 mm
Cylinder Diameter	302 mm
Cylinder Track Width	750-2500 mm
Cylinder Set Rotary Mass	4 x 120 kg
Supply Voltage	220 / 380 V
Insurance	16A / 25A
Air Pressure (Wheel Lift) min/max	6 Bar/10 Bar
Axle Range min (Moving Mechanism)	2200 mm
Axle Range max (Moving Mechanism)	3300 mm
Remote Control	50m
Electronic Control Unit Supply	220V
Body Lighting	12V Led Strip
Cylinder Surface	CNC Machining 2mm Diamond Pattern
Moveable Dynamometer Feature	2.2 Kw Motor with Magnetic Brake Reducer Gear Motion System
Air Compressor	50 lt / 198 lt min / 2,850 rpm min 8 Bar
Safety Device	12 mm Transmit Hook / Chain

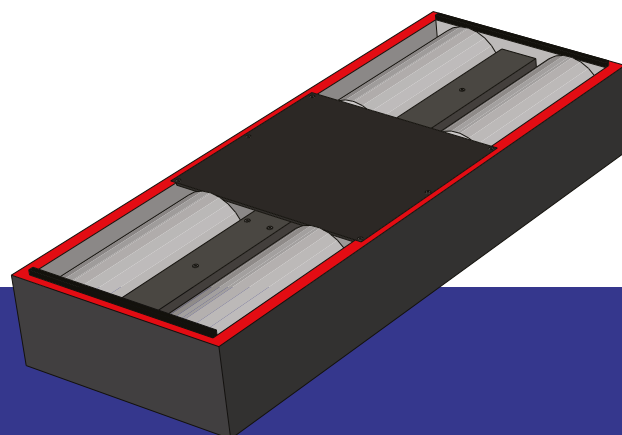

BRAKE TEST DEVICE

Brake Test Device checks the brake system elements that affect braking performance. Braking performance in the vehicle is of great importance in terms of revealing the condition of the brake system. The brake system, which is the most important part of the safety of the vehicle, does not accept any room for error.

The following measurements are made with the Brake Test Device:

- Control of rear braking restriction
- Stability control by braking
- Measurement of pedal force
- Determination of brake force and balance
- Determination of friction caused by rolling
- Measurement of maximum braking force of all four wheels
- Values of front and rear left and right brakes
- Percentage calculation
- ABS front brake control
- Percentage Reference Control Measurement According to European Standards

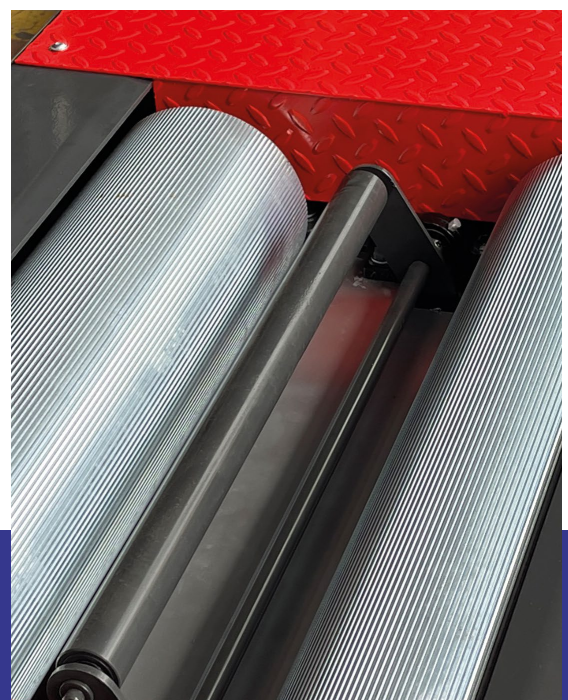
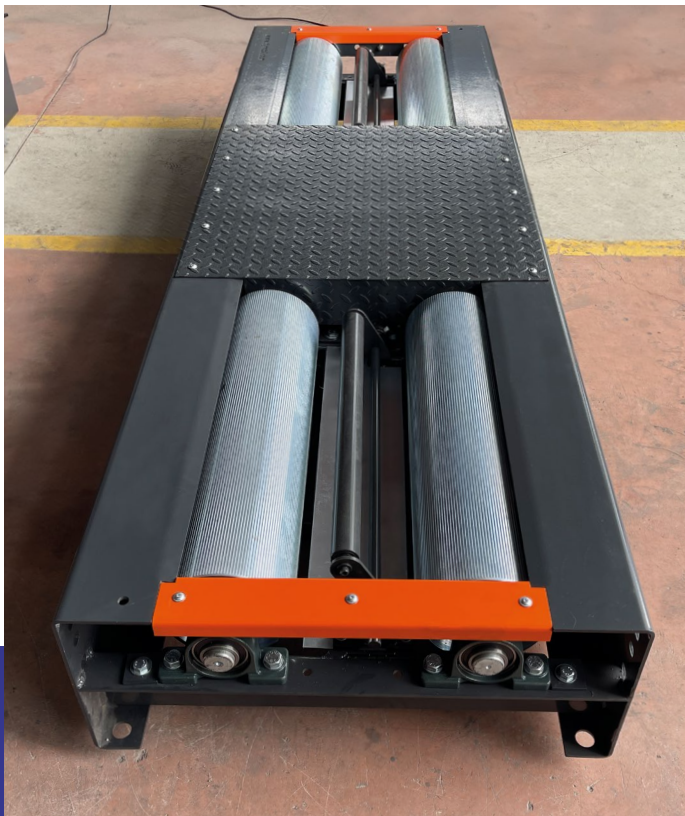
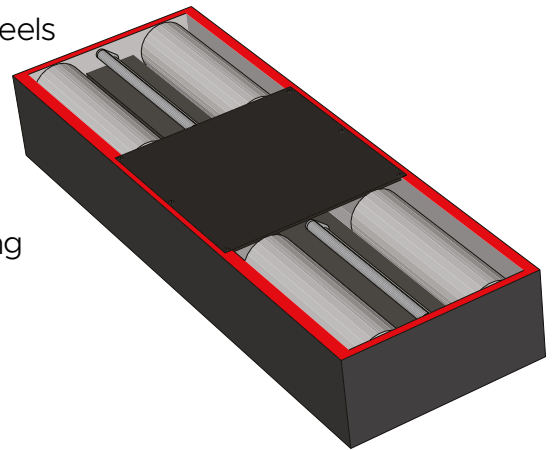

Malfunctions that can be detected with Brake Tester:

- Detection of brake drums or calipers with braking difference and holding force loss
- Detection of friction between disc pads and the road compared to the vehicle's weight and identification of faults in the wheel's grip efficiency on the road surface due to braking efficiency.
- Detection of oscillations that may arise from the brake disc through ovality (runout test).
- Control of the handbrake mechanism with the handbrake test.
- Detection of the response and oscillations of cyclic movement in graphs with pedal force measurement.

Technical Specifications	
Driving Direction	Double Direction
Measurement Accuracy	± %1
Axle Weight	3.500 kg
Weight	580 kg
Max Measurement Speed	5 km/s
Brake Power	8 Kn
Measure	2500x810x330 mm
Cylinder Diameter	200 mm
Cylinder Track Width	700-2500 mm
Cylinder Set Rotary Mass	4 x 80 kg
Supply Voltage	220 / 380 V
Insurance	16A / 25A
Body Lighting	12V Led Strip
Cylinder Surface	CNC Machining 2mm Grooved Surface
Engine Power	2 x 2.2 Kw



SUSPENSION TEST DEVICE

The suspension system, which is the main comfort element of vehicles, is one of the elements that provide driving comfort with the coordinated operation of many parts. The suspension test is calculated in accordance with EUSAMA criteria and literally measures the weight variations of the vehicle weight on the road while driving. You can check the entire suspension system in a closed and safe area and get clear results by detecting possible malfunctions.

Measurements are made with the Suspension Tester:

- Minimum Tractive Force of Four Wheels
- Minimum Grasp Frequency
- Checking Coil Springs
- Checking Shock Absorber Shafts
- Shock Absorber Mounts Inspection
- Vehicle Weight
- Force Amount with the Principle of Vibration
- Criteria Test for EUSAMA

Malfunctions that can be detected with Suspension Tester:

- Springs
- Shock absorbers
- Hanger System
- Balance Bars
- Rotils

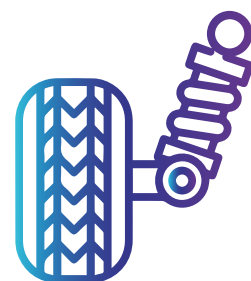

Technical Specifications	
Axle Weight	3.500 kg
Weight	380 kg
Vibration Amplitude	6 mm
Vibration Frequency	24 hz
Measure	2500x550x330 mm
Supply Voltage	220 / 380 V
Insurance	16A / 25A
Body Lighting	12V Led Strip
Loadcell count	4 pieces
Engine Powe	2 x 3 Kw

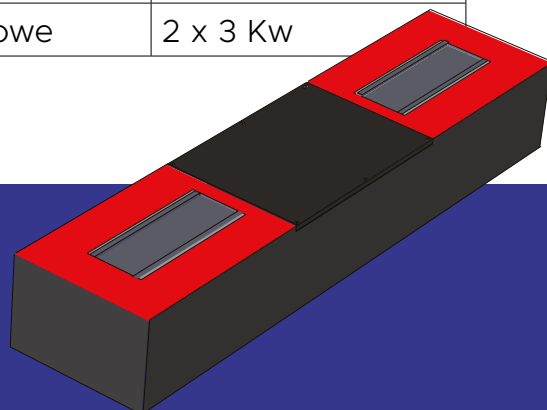

SIDE SLIP TESTING MACHINE

With the Lateral Slip Test Device, the compatibility of the front and rear tires of the car is measured. In this test, it is determined how much the car deviates when the steering wheel is released while the car is travelling along a one kilometer straight road. This test is completed with only 1 meter of movement of the device.

The Lateral Slip Test Device checks the tie rod adjustment, i.e. TOE angles, on the front and rear axles, which is one of the most important elements of safe driving.

Malfunctions that can be detected with Side Slip Test Device:

- Gaps between tie rods and vehicle axle
- Wheel Alignment Adjustment
- Axle Positions
- Disturbances in the lateral slip of the vehicle

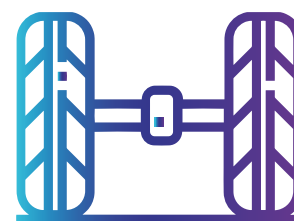

Technical Specifications	
Axle Weight	3.500 kg
Weight	35 kg
Test Range	± 50 mm
Vibration Frequency	23 hz
Dimension	62x62x14 mm
Supply Voltage	5 V

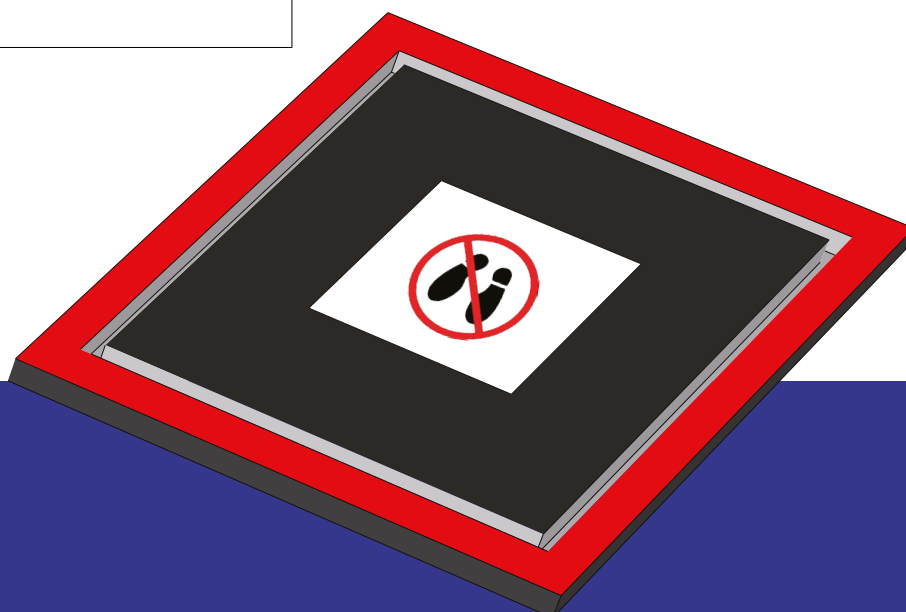

INDUSTRIAL TYPE FAN

Industrial Type Fan is manufactured to provide fresh air during the dynamometer test of the vehicle. The main purpose of use is to provide the air flow required during the test and to keep the temperature in the power pack under control.

Technical Specifications	
Cooling Capacity	26.000m3
Operating voltage	230-400V
Maximum Power Output	2,2Kw
Maximum Wind Speed	50Km/s - 90 Km/s
Cranking Speed	1450Rpm
Dimension	81cm * 78cm * 49cm
Mobile and Transportable System	
Wheel Locking Safety System	
Period of Guarantee	1 year

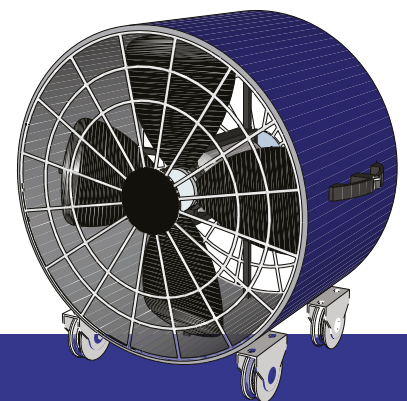
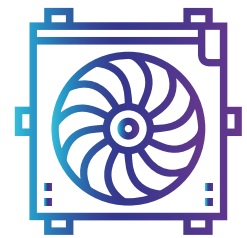

IN-VEHICLE VOICE CONTROL

In-vehicle Sound Control Device is a device that applies movement to the wheels in the desired vibration range with the vibration feet placed under the vehicle. These movements are controlled by an adjustable control between 0Hz-50Hz. During the vibrations, the operator performs fault detection safely and securely under the vehicle.

It is used in the control of all parts in the vehicle sub-equipment and in the detection of malfunctions. **External noises and defective parts seen in the vehicle are detected in the fastest and safest way.**

Technical Specifications	
Maximum output power	2,2 kw
Maximum operating frequency	50Hz
Operating voltage	230-400V
Course Mobility	±20
Engine Operating Speed	1450Rpm
Maximum Strength	3000Kg
Wheel Pressing Surface That Can Turn Right and Left	
Movable Drum Surface to Provide Wheel Rotation	
Dimensions	61cm * 50cm * 101cm
Portable Body and Side Step	
Wheel Locking Safety System	
Adjustment of floor fixing feet	
Period of Guarantee	1 Year

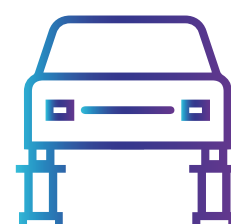

ROBOTIC VEHICLE BODY IMAGING AND ANALYSIS DEVICE

The vehicle body imaging device is designed to assess the current condition of vehicle bodies, detect any damage or defects that may have occurred later on. With its technology, it can distinguish between the original micron values of the vehicle and those of subsequently applied paint processes. **It has the capability to view in detail both repaired areas and the entire damaged area.**

Production is carried out with two different installation options.

1. Vehicle body imaging machine mounted on the ceiling.
2. Vehicle body imaging machine mounted on a support..

Equipped with advanced technology, it offers both automatic automation and manual vehicle imaging options, providing measurement results with precise values and presenting reports on the vehicle's paint flaws and damaged areas.

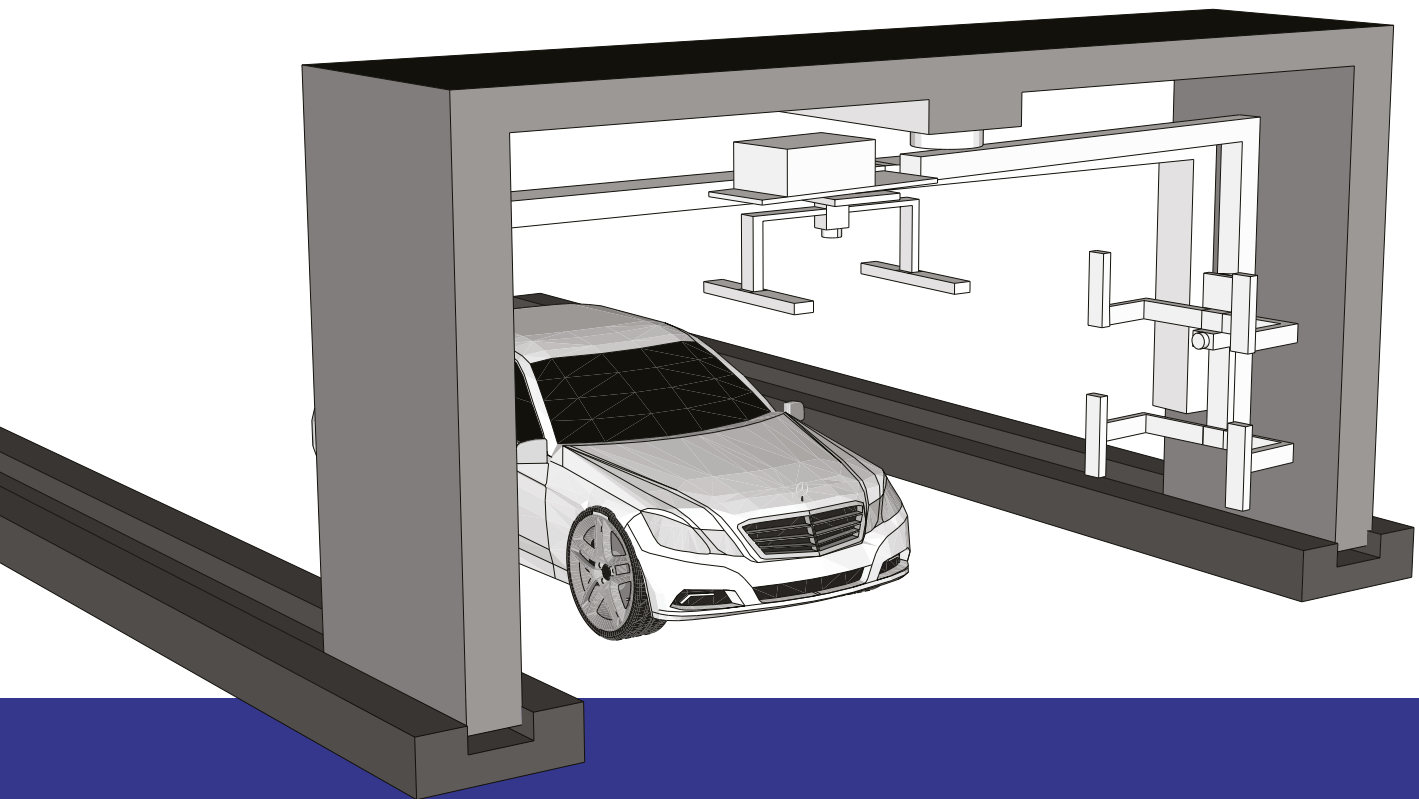

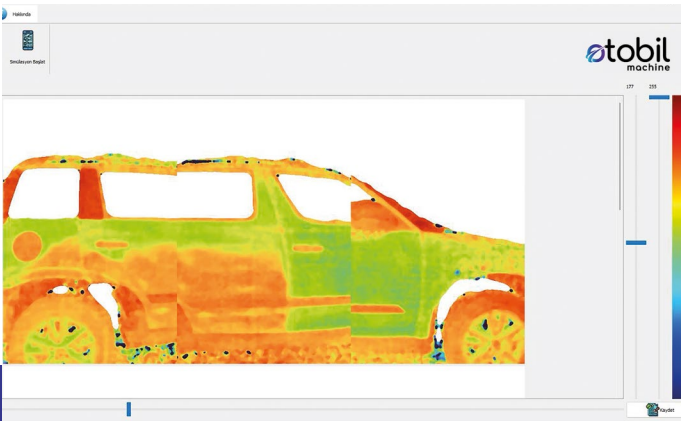

03

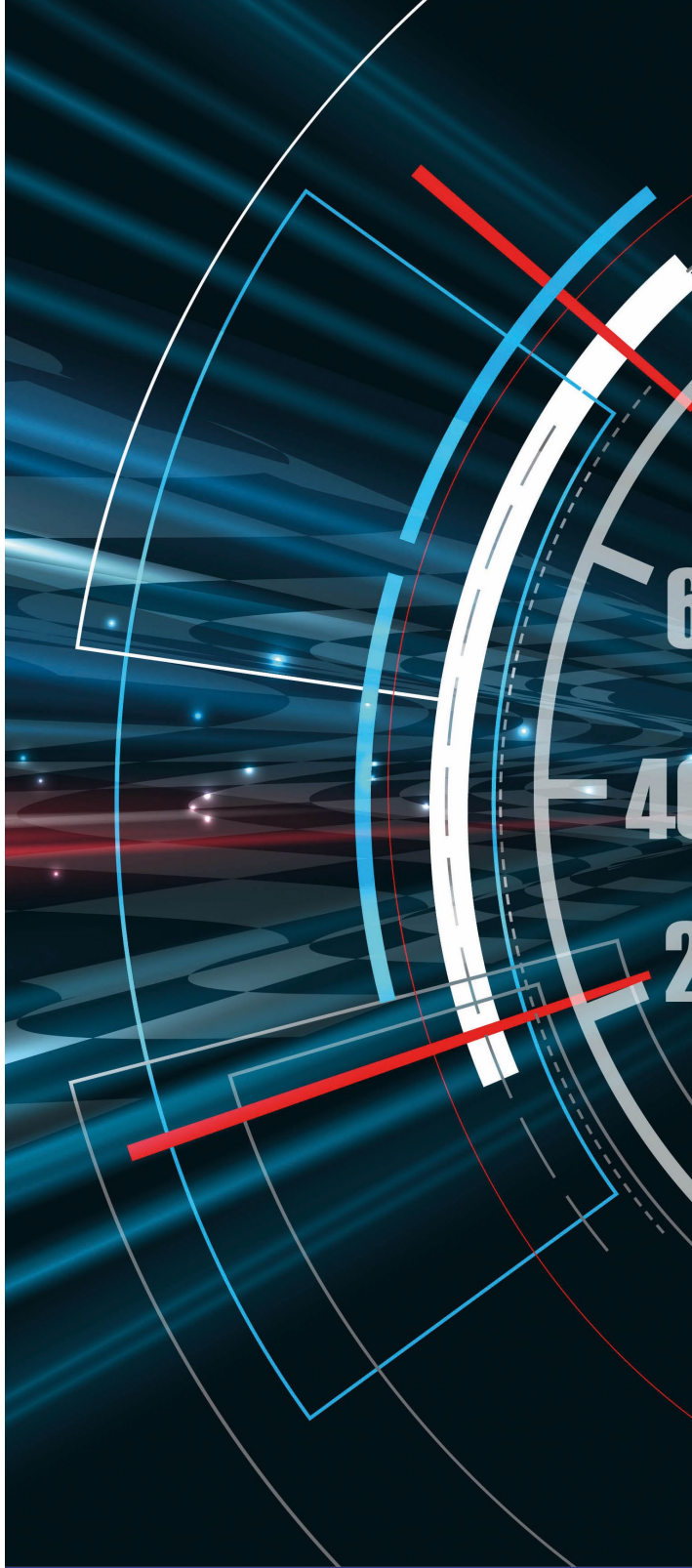



SOFTWARE AND INTEGRATION

OTOBİL V2 PROGRAMME



- The Otopil V2 program has been developed using the .net infrastructure.
- It is an independent test interface for end users.
- There is no API support in V2 system.
- In the V2 system, a distinction can be made between dealer users for device and test center formations.
- The V2 system offers device users special detailed settings (such as report design, usage with brand logos, etc.).
- It can be connected to electronic brains via 2 separate options: COM and Ethernet connection.
- Real-time data flow is provided from electronic brains.
- The data received in real-time is presented to the user after calculations made on the background algorithm.
- In addition to corporate companies, works have been carried out using the WPF-Blazor infrastructure.

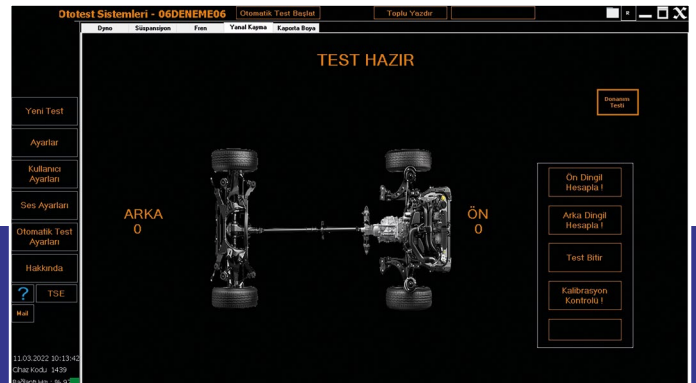
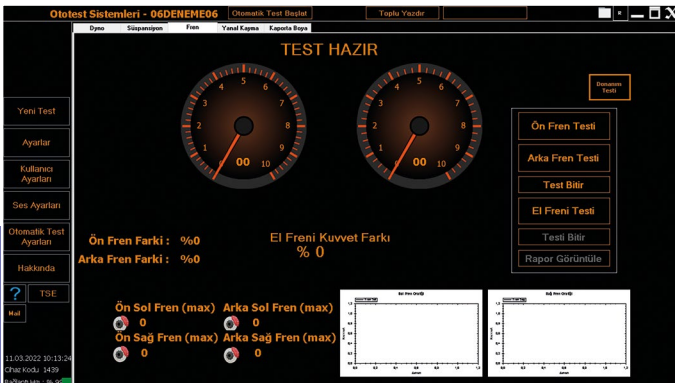
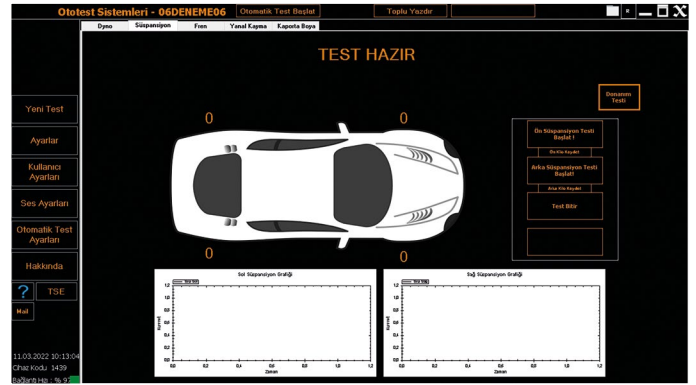

OTOBIL V3 PROGRAMME



- The Otobil V3 program has been prepared with the .Net infrastructure.
- It is specially designed for corporate users.
- DevExpress is used for visual purposes.
- The V3 system has Restful API support.
- JWT is used for connections in the V3 system.
- There is a mobile application available in the V3 system, and transactions can also be carried out through the mobile application.
- The web management system in the V3 system is more detailed and more secure.
- Vehicle inspection procedures can also be performed through the web interface in the V3 system.
- Accounting operations such as dealers and management, revenue, profit distinction, invoice sending, and invoice requesting services can be actively used in the V3 system.
- E-commerce can be conducted through the V3 system. (Custom products for the company)
- The mobile application offers the option of photo-based expert assessment.
- It can be connected to electronic brains via 2 separate options: COM and Ethernet connection.
- Instant data flow is provided from electronic brains.
- The data received in real-time is presented to the user after calculations made on the background algorithm.
- In addition to corporate companies, studies were carried out using WPF - Blazor infrastructure.

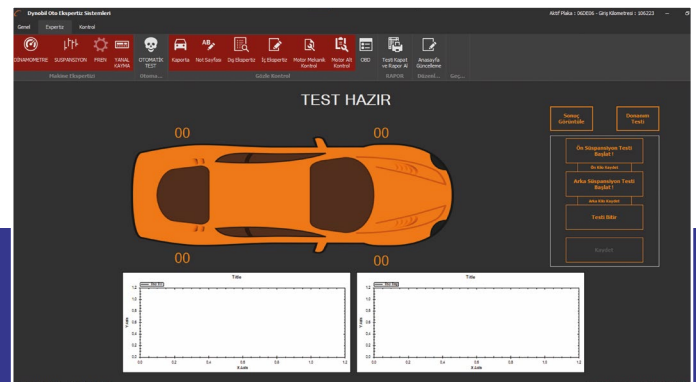
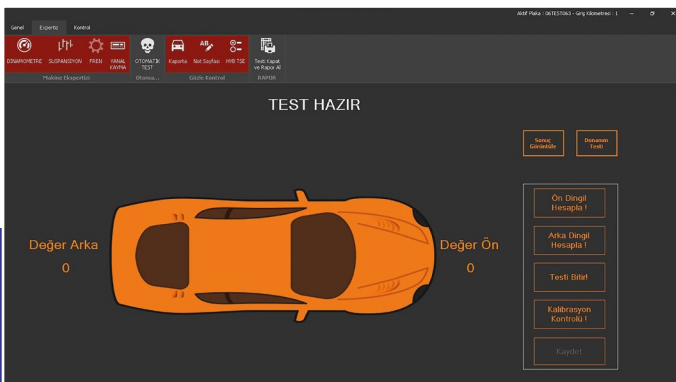
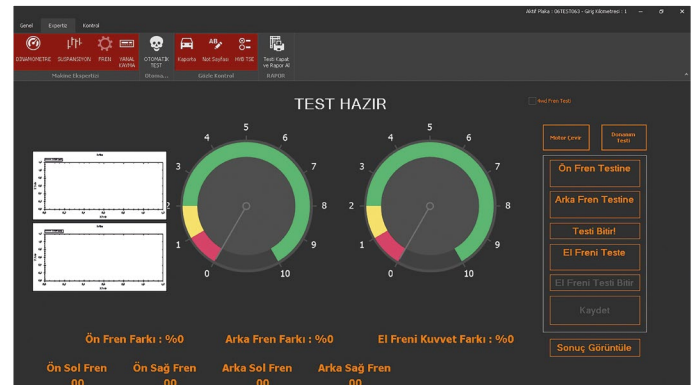

OTOBIL VX PROGRAMME

SPECIAL PERFORMANCE TEST SOFTWARE



- The Otoobil VX program has been developed using the .Net infrastructure.
- It is an independent test interface for the end user.
- The VX system does not have API support.
- Distinction can be made between dealer users for device and test center formations in the VX syste.
- Special detailed settings are available for device users in the VX system (such as report design, usage with brand logos, etc.).
- It can be connected to electronic brains via 2 separate options: COM and Ethernet connection.
- Instant data flow is provided from electronic brains.
- The data received in real-time is presented to the user after calculations made on the background algorithm.
- In addition to corporate companies, studies were carried out using WPF-Blazor infrastructure.

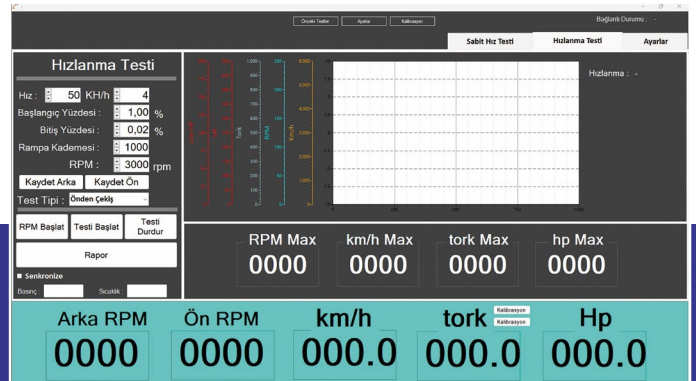
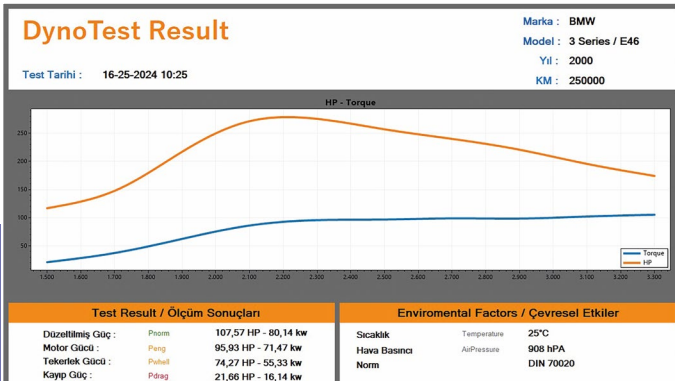
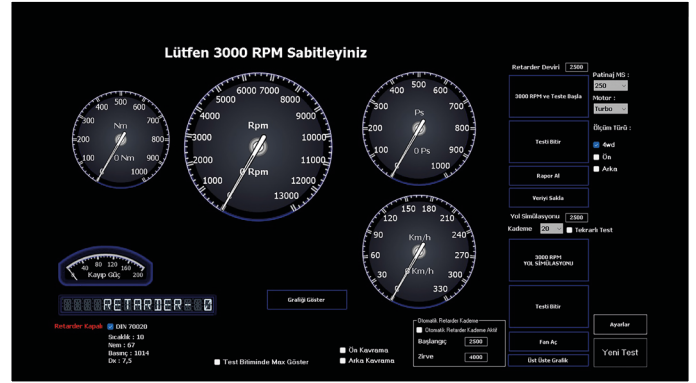
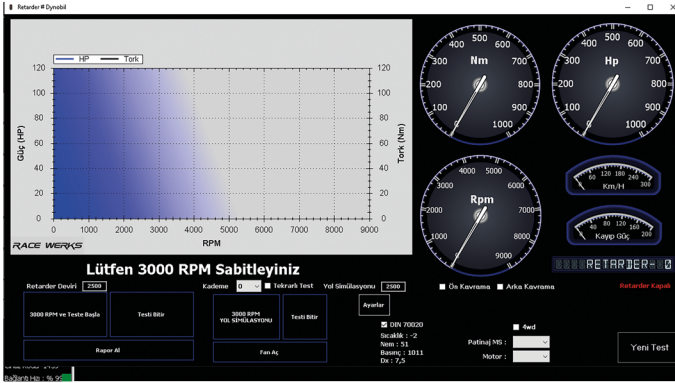

04





OUR REFERENCES

- NERO Endüstri Savunma A.Ş.
- Erkunt Traktör Sanayi A.Ş
- Borusan Otomotiv
- Ford Otosan
- Otokoç Otomotiv
- Fiat Birmot Authorised Services
- Hyundai Authorised Services
- DoğuŖ Oto
- Auto Expertise Companies
- Sahibinden.com
- Volkswagen Authorised Services
- KGEVIS
- KEYTECH
- CARVAK

www.otobilmachine.com

İvedik Osb Mah. Öz Marangozlar Sit. 2239/1 Sk. No:9
Yenimahalle/Ankara

